

ABB solar inverters

Quick Installation Guide

PVS-50-TL PVS-60-TL

(50 to 60 kW)

EN



In addition to the information given below, it is mandatory to read and observe the safety information and installation instructions shown in the product manual. The technical documentation and the interface and management software for the product are available on the website. The equipment must be used and installed in accordance with what is described in this Quick Installation Guide, paying attention to follow the installation sequence exactly as described. Otherwise, the safety devices guaranteed by the inverter may be ineffective.



Inverter Models and Components

The inverter model should be chosen by a specialized technician who has a good knowledge of the installation conditions, the devices that will be installed externally, and whether it will eventually be integrated into an existing system. Based on the output power there are two inverter families:

Inverter model	Input channel	DC switch	DC SPD	DC connection	String fuses	AC SPD	Display	DC SPD class 1+2
PVS-50(60)-TL	1	No	Class 2	screw terminal blocks	No	Class 2	optional	No
PVS-50(60)-TL-S	1	Yes	Class 2	screw terminal blocks	No	Class 2	optional	No
PVS-50(60)-TL-SX	3 (1 if paralleled)	Yes	Class 2	15 pairs quick fit connectors	positive	Class 2	optional	No
PVS-50(60)-TL-SX2	3 (1 if paralleled)	Yes	Class 2	15 pairs quick fit connectors	positive and negative	Class 2	optional	optional

Main Components			
01 Mounting bracket	19 Input quick fit connectors (channel 1)	50 Interposer board	
02 Locking brackets	20 Input quick fit connectors (channel 2)	51 ALARM (multifunction relay) terminal block	
03 Inverter/bracket anchor points	21 Input quick fit connectors (channel 3)	52 AUX (multifunction relay) terminal block	
04 Wiring box front door	22 Anti-condensation valve	53 RS485-1 and RS485-2 lines, R1 ON/OFF and R2 ON/OFF (remote ON/OFF) and 5V auxiliary lines terminal block	
05 LED panel	23 Cooling section	54 RS485-1 line 120Ohm termination resistor switch	
06 Display	24 Lower support	55 RS485-1 communication card housing	
07 Keypad	25 Communication and control board	56 RS485-1 line connection on RJ45 connector	
08 Key lock	26 Grounding kit (optional kit)	57 RS485-2 line connection on RJ45 connector	
09 Lifting ring	27 DC overvoltage surge arresters	58 RS485-2 line 120Ohm termination resistor switch	
10 Wi-Fi antenna connector	28 DC disconnect switch	59 RS485-2 communication card housing	
11 Locking brackets attachment point	29 Negative (-) side string fuses	60 RS485 Main terminal block (J5)	
12 Ethernet cable gland	30 Positive (+) side string fuses	61 Battery housing	
13 Service cable gland	31 AC overvoltage surge arresters	62 SD card housing	
14 Handle	32 Protective earth terminal (internal)	63 Grounding kit connector (optional kit)	
15 DC disconnect switch	33 AC output screw terminal block	64 Inverter data memory card housing	
16 Protective earth terminal (external)	34 DC input screw terminal block	65 Ethernet connector	
17 DC cable glands	35 AC filter board		
18 AC cable gland	36 Parallel MPPT connection points		

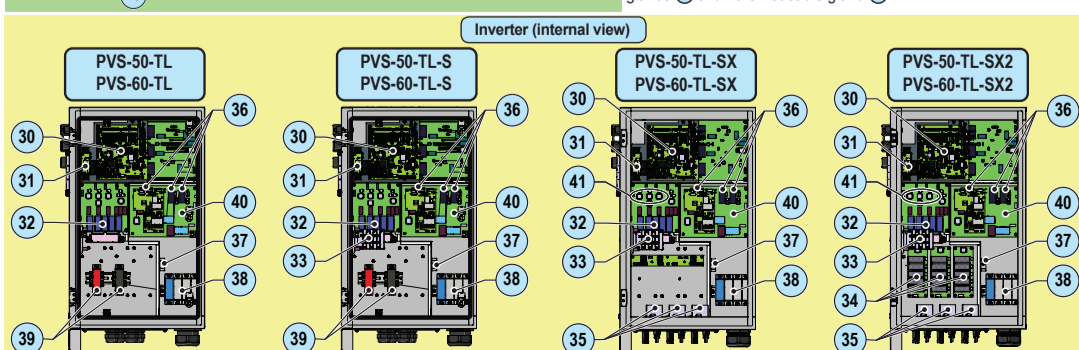
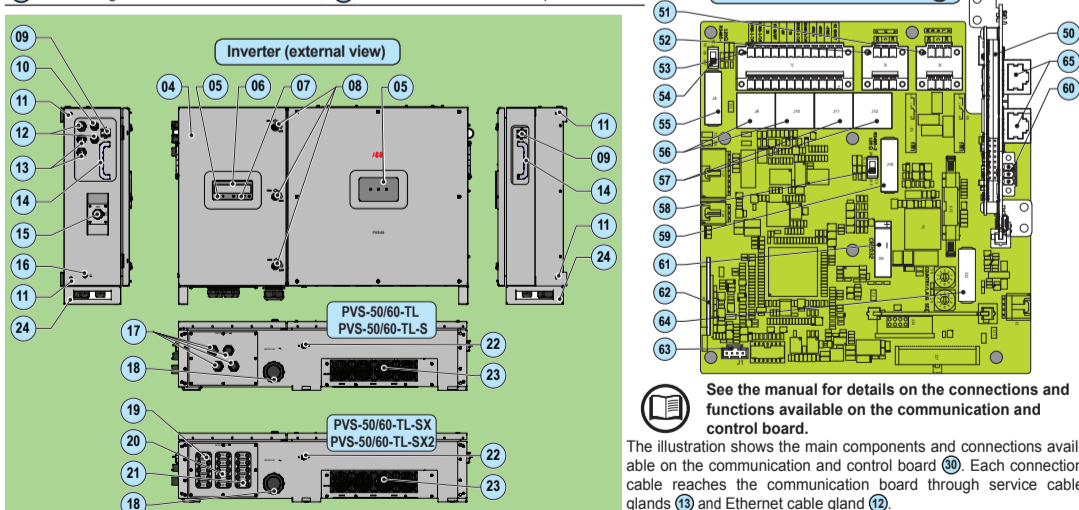

1. Labels and Symbols

The labels on the inverter show the conformity marking, main technical data and identification of the equipment and manufacturer. The below labels are intended as an example only; in fact, other models of inverter are available.

Regulatory Label

Identification Label

WLAN board Serial Number
WLAN board Part Number/MAC address:
MAC address:
 - To be used to obtain the SSID of the wireless access point created by the inverter: ABB-XX-XX-XX-XX-XX-XX (where "X" is a hex digit of the MAC address).
 - To be used to obtain the "Host Name": http://ABB-XX-XX-XX-XX-XX-XX.local (where "X" is a hex digit of the MAC address).
 - MAC address it's the only required information to register the inverter with Aurora Vision.
Inverter Serial Number
Product Key:
 To be used as wireless access point password, or to be used to access to the Web UI as username and password in case of lost credentials, and to commission inverter using "Installer for Solar Inverters" mobile APP.

2. Installation site

The labels placed on the equipment MUST NOT be removed, damaged, dirtied, hidden, etc... In the manual and/or in some cases on the equipment, the danger or caution areas are indicated with signs, labels, symbols, or icons.

Always refer to the manual	General warning – Important safety information	Hazardous voltage	Hot surfaces
Protection rating of equipment	Temperature range	Without insulation transformer	Direct and alternating current, respectively
Positive and negative poles of the input voltage (DC)	Always use safety clothing and/or personal protection equipment	Point of connection for grounding protection	Stored energy discharge time

3. Installation site (continued)

- Consult technical data to confirm the environmental specifications will be met.
- Installation of the unit in a location exposed to direct sunlight is acceptable. Except for the version equipped with a display.
- Do not install in closed spaces where air does not freely circulate.
- Always ensure that the flow of air around the inverter is not blocked, so as to prevent overheating.
- Do not install near flammable substances (minimum distance: 3 m).
- Do not install near wooden walls or near flammable surfaces.
- Do not install in rooms where the people live or where the prolonged presence of people or animals is expected.
- Installation of these models can be carried out vertically or horizontally with a maximum inclination as indicated in the figures.
- Hardware and software maintenance on device entails opening the front door. Check that the correct installation safety distances are observed in order to allow routine check and maintenance operations.
- Install on a wall or strong structure suitable to bear the weight.
- If possible, install at eye-level so that the status LEDs can be seen easily.
- Install at a height which takes into consideration the weight of the appliance and in a position which is suitable for servicing, unless suitable means are provided to carry out the operation.
- Final installation of the device must not compromise access to any disconnection devices that may be located externally.
- Respect the minimum distances from objects around the inverter that could prevent the inverter installation and restrict or block the air flow.
- Provide sufficient working space in front of the inverter that allows to make connections on the wiring box.
- In case of multiple installation position the inverters side by side keeping the minimum distances (measured from the outer edge of the inverter) for each inverter. If the space available does not allow this arrangement, position the inverters in a staggered arrangement as shown in the figure so that heat dissipation is not affected by other inverters below.
- The vertical installation is also permitted on a structure which must be composed of a support for the attachment of the bracket and one for the support of the rear pins.
- The vertical installation of two inverters positioned back to back is also permitted on a structure which must be composed of 2 supports for the attachment of the brackets.
- The inverter operates normally up to 2000 meters; between 2000 and 4000 meters the inverter works in derating (to verify curve derating), above 4000 meters the installations are forbidden.
- Never open the inverter in the case of rain, snow or a level of humidity >95%.

Do not block access to the external AC and DC disconnect switches. Please refer to the warranty terms and conditions and avoid voiding the warranty with improper installation.

4. Transport and Handling

Transport of the equipment especially by road, must be carried out with means for protecting the components (in particular, the electronic components) from violent shock humidity vibration etc. During handling, do not make any sudden or fast movements that can create dangerous swinging.

Lifting
 ABB usually stores and protects individual components by suitable means to make their transport and subsequent handling easier, but as a rule, it is necessary to utilize the experience of specialized staff in change of loading and unloading the components. Do not lift several units or parts of the equipment at the same time unless otherwise indicated.

The ropes and equipment used for lifting must be suitable for bearing the weight of the equipment.

Unpacking and Checking
 The packaging components must be removed and disposed of according to all applicable laws and regulations of the country where the equipment is being installed. When you open the package, check that the equipment is not damaged and make sure all components are present. If you notice any defects or damage, stop unpacking and contact the carrier, and also promptly inform the ABB Service department.

Model	Weight
PVS-50-TL / PVS-60-TL	70 kg/159lbs

5. List of Supplied Components

Components available for all inverter models	Q.ty	Components available for all inverter models	Q.ty
Mounting bracket (01) + screws for bracket mounting	1 + 6	M6 screw for securing the: - Protective earth terminal (internal) (16) - Protective earth terminal (external) (17)	2
Locking brackets (02) + screws for the locking bracket mounting	4 + 8	M6 toothed washer for securing the: - 2x Protective earth terminal (internal) (16) - 2x Protective earth terminal (external) (17)	4
Configurable relay connectors	2	WiFi antenna	1
Control and communications signal connectors	2	Configuration bar for paralleled input channels and M5x12 screws (with plain and split washers)	1 + 3
Two-hole gasket for PG 21 signal cable glands (13) + cap	2 + 2	Key for front door key-lock (08)	
		Technical documentation	

6. Mounting Instructions

Mounting of the inverter on the bracket

The mounting bracket (01) can be used to install the inverter on a vertical or horizontal support.

- Position the bracket (01) perfectly level on the support and use it as a drilling template. (FIG. 1)
- It is the installer's responsibility to choose an appropriate number and distribution of attachment points. The choice must be based on the type of support (wall, frame or other support), the type of anchors to be used and their ability to support 4 times the inverter's weight (4 x 70 kg=280 kg for all models). Attach the bracket to the wall with at least 10 attachment screws. Depending on the type of anchor chosen, drill the required 10 holes (A) to mount the bracket. Put at least four screws in the upper side and at least four in the lower side (see example in the illustration).
- Fix the bracket to the support. (FIG. 2)
- Lift the inverter using the handles (09), or another appropriate lifting device. The inverter is pre-equipped with lower support (24) which allow it to be temporarily put vertically on the floor to make it easier the lifting. (FIG. 3 and 4)

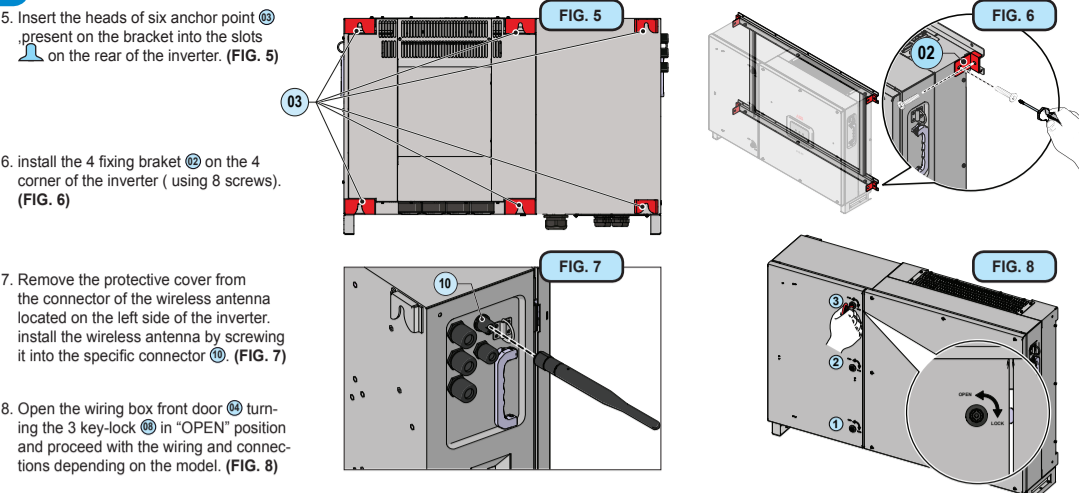

Load Protection Breaker (AC Disconnect Switch) and Line Cable Sizing

To protect the AC connection line of the inverter, we recommend installing a device for protection against over current with the following characteristics.

	PVS-50-TL	PVS-60-TL
Type	Automatic circuit breaker with thermal magnetic protection	
Rated Voltage/Current	400 V / 100 A	480 V / 100 A
Magnetic protection characteristic		B/C
Number of poles		3/4
Type of differential protection (if required)		A/AC
Differential sensitivity (if required)	500mA for PVS-50-TL and 600mA for PVS-60-TL	

Characteristics and Sizing of the Line Cable
 The AC connection is three-phase (three-wire connection 3W+PE or four wire connection 4W+PE, grounded only WYE system). The cross-section of the AC phase conductor must be appropriately sized in order to prevent unwanted disconnection of the inverter from the distribution network due to high impedance of the line that connects the inverter to the power supply point.

To avoid risks of electrical shock, all wiring operations must be carried out with the disconnect switch downstream of the inverter (grid side) opened and applying LOTO procedure on it. Be careful not to change round one of the phases with neutral!

Grounding connection is essential before connection to the power supply network.

In compliance with standard IEC 62109 it is necessary:
 Install an earthing cable in one of the protective earth terminal with a minimum section as indicated in the table below:

Cross-sectional area of phase conductors (S) (mm ²)	Minimum cross-sectional area of the protective earthing conductor (mm ²)
S ≤ 16	S
16 < S ≤ 35	16
35 < S	S/2

The value on this table are valid only if the protective earthing conductor is made of the same metal as the phase conductors. If this is not so, the cross-sectional area of the earthing conductor is to be determined in a manner which produces a conductance equivalent to that which results from the application of this table.

It is possible to install a second earthing cable (with the same section as the first one) positioning it in the protective earth terminal not used (internal or external). Installation of a second protective earth cable is also required by regulations in force in certain countries of installation.

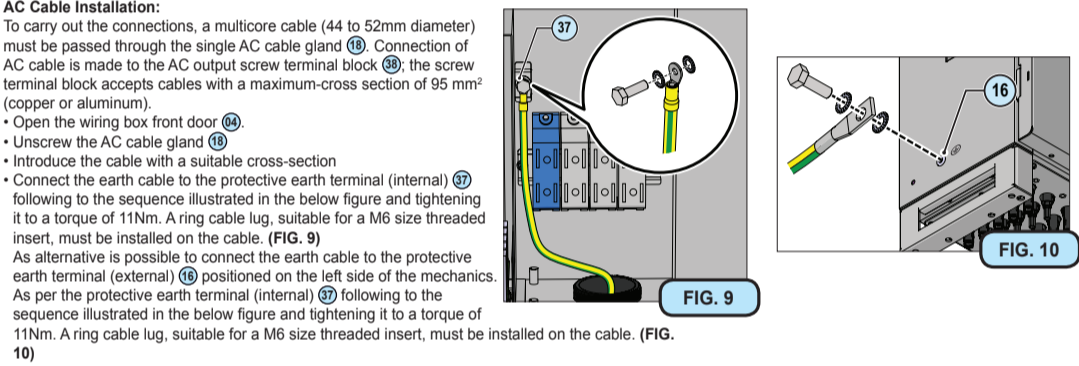

Description of the LEDs located on the inverter cover:

POWER LED	GREEN On, if the inverter operates correctly. Flashes in the network control phase or if the sunlight is not enough.	
ALARM LED	YELLOW The inverter has detected a fault. For inverters with a display, the error/warning message appears on the display.	
GFI LED	RED Ground fault of the PV array, DC side. For inverters with a display, the error message appears on the display.	

Refer to the product manual for a description of error/warning codes appearing on the display, for inverters with a display.

Before starting the inverter commissioning procedure, ensure that all the checks indicated in the previous sections of this Quick Installation Guide have been correctly performed and also that the front door have been correctly closed! Make sure irradiation is stable and adequate for the inverter commissioning procedure to be completed.

Commissioning could be carried out in two different ways:
 - Via "Installer for Solar Inverters" mobile APP
 - Via Web UI (access point wireless network)

COMMISSIONING VIA "INSTALLER FOR SOLAR INVERTERS" MOBILE APP
 "Installer for Solar Inverters" is the new advanced ABB mobile APP allows to simplify commissioning, parameter settings and troubleshooting of ABB string multi-inverters in large scale solar plants. Even in case of single inverter installation it can be considered the most suitable professional tool to be used.

Commissioning procedure:
 It's highly recommended to connect the inverters in ethernet daisy chain (with or without ring) before executing the commissioning procedure. Make sure that all the inverter being commissioned features the last firmware version (updating can be executed via Installer for Solar Inverters mobile APP).

Make sure irradiation is stable and adequate for the inverter commissioning procedure to be completed.

The main steps to complete the commissioning procedures are listed below:
 - Installer for Solar Inverters mobile APP installed on mobile device.
 - Enabled Aurora Vision installer account allowed to use the mobile APP. The account can be created in the mobile APP directly following the dedicated wizard procedure.
 - Manual claiming of the inverters to be commissioned.
 - Claiming process consists of indicating which inverters are to be commissioned.
 - Claiming process can be executed by scanning the QR codes of all the inverters being worked and putting the selected inverters into the working list. Please insert in the list inverters belonging to the same inverters family, no more than 40 inverters by time can be configured together.
 - As an alternative of QR code scanning, claiming process can be executed by selecting manually the SSIDs associated to the Wi-Fi networks generated by each inverter to commission and inserting Product key when requested.
 - Both QR code and Product key are provided on the Communication identification label stuck onto each inverter.
 - The Communication Identification label is divided in two separate parts by a dashed line; take the bottom part and apply it on the plant documentation. (it's recommended to create a plant map and apply the Communication Identification label of each inverters in the right position of that map).

Above steps are valid for executing any available functionalities of the Installer for Solar Inverters mobile APP.
 - In order to launch the installation wizard and so complete the commissioning procedure please click "Commissioning" button. If needed click prevently on "Firmware update" button for aligning the firmware of all the inverters in the list to the last version (internet connection is needed).

For more details about commissioning and any other functionalities of the Installer for Solar Inverters mobile APP please contact ABB customer support. For any other specific settings of parameters of single inverters please refer to "Description of the Web User Interface" chapter.

COMMISSIONING VIA WEB UI (ACCESS POINT WIRELESS NETWORK)
 The inverter can be commissioned and configured from a wireless device, such as a Smartphone, a tablet or a laptop. The commissioning procedure is as follows:
 1. Supply the input voltage from the photovoltaic generator to the inverter.
 2. Enable the wireless functionality on the device you are using for the commissioning of the inverter the network named ABB-XX-XX-XX-XX-XX, where "X" is an hexadecimal number of the MAC Address (the MAC Address is indicated on the "wireless identification label" on the side of the inverter).
 3. When prompted, type the "product key" (including the dashes. Example: 1234-1234-1234-1234) as the network password.
 4. Open your Internet browser (recommended browsers: Chrome from v.55, Firefox from v.50, Safari from V.10.2.1) and enter the default IP Address to access the Configuration Wizard page: 192.168.117.1.
 5. This will start the Configuration Wizard:
 - STEP 1 - Set the Admin/User access credentials (at least 8 characters for the password). Username and password are CASE SENSITIVE.
 - STEP 2 (OPTIONAL) - Enter the required information (IP Address selection mode, SSID, and password) to connect the inverter to the wireless network. A new message will be displayed showing the IP Address assigned by router to access to the internal Web server. TAKE NOTE OF THE LINKS.
 - STEP 3 - Set the Date, Time and Time Zone.
 - STEP 4 - Set the inverter grid standard and configure the input channels.
 By clicking "FINISH" the wizard completes the configuration procedure (after the settings are confirmed, the inverter restarts).

From the moment the grid standard is selected, there will be 24 hours available to make any changes to the grid standard; after this, the "Country Select" feature is blocked and you can make further changes only by resetting the remaining-time timer.

Supply the grid voltage to the inverter. Once the AC and DC disconnect switches are closed and the Configuration Wizard has completed the configuration procedure, the inverter starts the grid connection sequence. If the outcome of the preliminary checks is positive, the inverter will connect to the grid and start exporting power. The "Power" LED remains solid on, while the "Alarm" and "GFI" LEDs are off.

For more information about the configuration and use of the internal Web server, refer to the product manual.

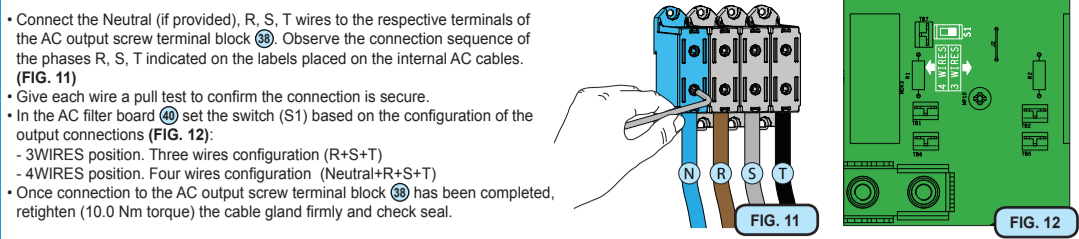

Comply with the maximum input current relating to the quick-fit connectors as indicated in the technical data. Polarity inversion can cause serious damage. Check polarity before connecting each string! When the photovoltaic panels are exposed to sunlight they provide continuous DC voltage to the inverter. To avoid risks of electrical shock, all wiring operations must be carried out with the DC disconnect switch internal and external (if present, applying LOTO procedures on it) to OFF position and with the external AC disconnect switch to OFF position (applying LOTO procedures on it).

In case presence of internal DC disconnect switch only, there will be live parts internal to the inverter with a consequent risk of electrical shock. In this case these activity is ONLY allowed with the use of appropriate PPE (overall resistant to electric arc, dielectric helmet with visor, insulating gloves class 0, Protective overglove in leather EN420 – EN388, Safety shoes).

Warning: The inverters referred to in this document are WITHOUT AN ISOLATION TRANSFORMER (transformerless). This topology implies the use of isolated PV panels (IEC61730 Class A Rating) and the need to keep the PV array floating with respect to ground: no terminal of the PV array must be connected to ground. For a different connection of PV strings, when a negative input grounding kit is installed, the use of an isolation transformer in mandatory. Refer to the "PVS-50/60-GROUNDING KIT" Quick Installation Guide for further information. If input strings are paralleled, they must have the same installation conditions (number of panel sets, panel type, orientation and tilt).

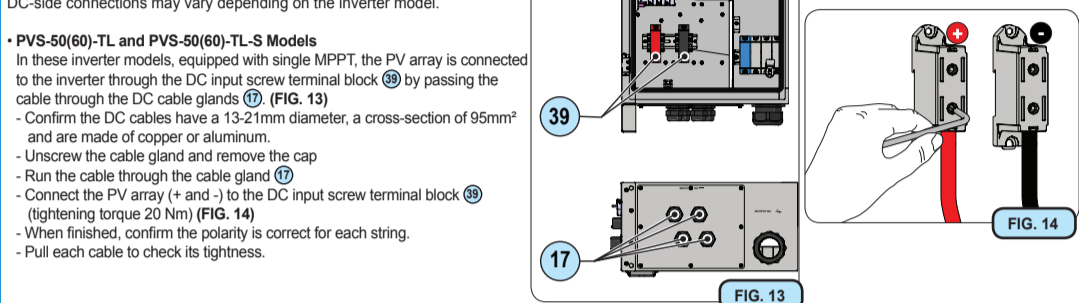

DC-side connections may vary depending on the inverter model.

PVS-50(60)-TL and PVS-50(60)-TL-S Models
 In these inverter models, equipped with single MPPT, the PV array is connected to the inverter through the DC input screw terminal block by passing the cable through the DC cable glands. Confirm the DC cables have a 13-21mm diameter, a cross-section of 95mm² and are made of copper or aluminum. Unscrew the cable gland and remove the cap. Run the cable through the cable gland. Connect the PV array (+ and -) to the DC input screw terminal block (tightening torque 20 Nm). When finished, confirm the polarity is correct for each string. Pull each cable to check its tightness.

PVS-50(60)-TL-SX and PVS-50(60)-TL-SX2 Models
 In these inverter models, the PV array is connected to the inverter through quick fit input connectors (MPPT) located at the bottom of the mechanics. Based on PV system configuration, inputs can be set as 3 independent MPPTs or as a single MPPT with the three paralleled input channels. Paralleled inputs can be obtained by installing the bar (provided) on the paralleled MPPT connection points using the 3 screws (M5x12, tightening torque 4.0Nm). An incorrect setting of the input channels can lead to loss of energy production. Quick fit connectors are divided into 3 groups (a group for each input MPPT), each composed of 5 couples of quick fit connectors. Refer to document "String inverters - Product manual appendix" available on ABB website www.abb.com/solarinverters to find out the make and model of the quick fit connector used on the inverter. Depending on the type of quick fit connectors installed on your inverter, you will have to use the same type for the corresponding counterparts (after checking for compliant counterpart on the manufacturer's website or with ABB).

The use of non-matching counterparts for the quick fit connectors installed on the inverter may seriously damage the inverter and invalidates the product warranty.

Connect all strings to the appropriate quick fit connectors (+ and -) following the site wiring diagrams e check the tightness of each single connection. If some string inputs are not used, ensure that caps are installed on the connectors; install them if missing. This operation is necessary for the tightness of the inverter and to avoid damaging the free connector that may be used at a later date.

	PVS-50-TL	PVS-60-TL
Input		
Maximum absolute input voltage (Vmax,abs)	420...700 V (default 420 V)	1000 V
Input activation voltage (Vstart)	0.7xVstart...950 V (min 300 V)	420...700 V (default 500 V)
Operating DC input voltage range (Vdcmín...Vdcmáx)	610 V	0.7xVstart...950 V (min 360 V)
Rated DC input voltage (Vdcr)	52000 W	720 V
Rated DC input power (Pdcr)	61800 W	61800 W
No. of independent MPPTs	3 (-SX and -SX2 versions) / 1 (standard and -S versions)	3
Maximum input power for each MPPT (PMPPT,max)	19300W@30°C / 17500W@45°C	23100 W@30°C / 21000 W@45°C
MPPT DC voltage range (VMPPPT min... VMPPPT max) at Pacr	480...800 V	570...800 V
Maximum DC input current (Idc max) for each MPPT	36 A	36 A
Maximum input current short circuit current (Idc max) for each MPPT	55 A (165 A for paralleled MPPTs)	55 A (165 A for paralleled MPPTs)
Maximum backfeed current (AC side vs DC side)	Negligible in normal operating conditions (3)	Negligible in normal operating conditions (3)
No. of DC input pairs for each MPPT	5 (-SX and -SX2 versions)	5 (-SX and -SX2 versions)
DC connection type	Screw terminal block (standard and -S models) / PV quick fit connector (4) (-SX and -SX2 models)	Screw terminal block (standard and -S models) / PV quick fit connector (4) (-SX and -SX2 models)
Types of PV panels that can be connected as input according to IEC 61730	Class A	
Input Protection		
Reverse polarity protection	Yes, from a limited current source	Yes, from a limited current source
Input overvoltage protection for each MPPT - SPD	Yes, 1 for each MPPT	Yes, 1 for each MPPT
Input overvoltage protection for each MPPT - Surge Arrester	Type II / Type I+II (optional)	Type II / Type I+II (optional)
Isolation control	Complying with the local standard	Complying with the local standard
Characteristics of the DC disconnect switch for each MPPT (models with DC disconnect switch)	1000 V / 60 A for each MPPT (180 A for paralleled MPPTs)	
String fuses (models with fuses)	15 A / 1000 V / gPV	
Output		
AC connection to the grid	3W + GND (no N connection) or 4W + GND (with N connection) Grounded WYE system only	
Rated AC output power (Pacr@cosφ=1)	50000 W	60000 W
Maximum AC output power (Pac max@cosφ=1)	55000 W up to 30°C	66000 W up to 30°C
Maximum apparent power (Smax)	55000 VA up to 30°C	66000 VA up to 30°C
Rated AC grid voltage (Vacr)	400 Vac	480 Vac
AC output voltage range (Vacmin...Vacmax)	320...480 Vac (1)	384...571 Vac (1)
Maximum AC output current (Iac max)	80 A	80 A
Contributory fault current	92 A	92 A
Rated output frequency (fr)	50 / 60 Hz	50 / 60 Hz
Output frequency range (fmin...fmax)	47...53 / 57...63 Hz (2)	47...53 / 57...63 Hz (2)
Rated power factor and adjustable range	> 0.995, 0...1 inductive/capacitive with max Smax	> 0.995, 0...1 inductive/capacitive with max Smax
Total current harmonic distortion	< 3%	< 3%
Maximum AC cable cross-section allowed	95 mm ² copper	95 mm ² copper
AC connection type	Screw terminal block, cable gland M63	
Output Protection		
Anti-islanding protection	Complying with the local standard (active frequency drift combined with RoCoF techniques)	
Maximum external AC overcurrent protection	100 A	100 A
Output overvoltage protection - SPD	Yes	Yes
Output overvoltage protection - Surge Arrester	Type II	Type II
Operating Performance		
Maximum efficiency (ηmax)	98.4%	98.6%
Weighted Efficiency (EURO/CEC)	98.2% / -	98.4% / -
Communication		
Integrated communication interface	3x RS485, 2x Ethernet (RJ45), WLAN (IEEE802.11 b/g/n @ 2.4 GHz)	
Communication protocol:	Modbus RTU / TCP (Sunspec compliant); Aurora Protocol	
Remote monitoring services	Standard level access to Aurora Vision monitoring portal	
Advanced features	Integrated Web User Interface; Display (option); Embedded logging and direct transferring of data to Cloud	
Environment		
Ambient temperature	-25...+60°C (-13...140°F) with derating over 45°C (113°F)	
Storage temperature	-40°C...+85°C / -40°F...185°F	
Relative humidity	4...100% condensing	
Sound pressure level, typical	75 dB(A) @ 1 m	
Maximum operating altitude	4000 m (13123 ft) with derating above 2000 m / 6561 ft	
Classification of the degree of environmental pollution for the external environment	3	
Environmental category	Outdoor	
Physical Specs		
Environmental protection rating	IP 65 (IP54 for cooling section)	
Cooling System	Forced air	
Dimensions (H x W x D)	750 mm x 1100 mm x 257 mm / 29.5" x 43.3" x 10.12"	
Weight	70 kg / 154 lbs (SX version)	
Mounting system	Wall bracket, horizontal support	
Overvoltage category according to IEC 62109-1	II (DC input) III (AC output)	
Safety		
Isolation level	Transformerless	
Marking	CE (3)	
Safety class	I	
	1. The output voltage range may vary depending on the specific grid standards of each country 2. The output frequency range may vary depending on the specific grid standards of each country 3. In case of failure, it is limited by the external protection device on the AC circuit 4. Refer to document "String inverters - Product manual appendix" available on ABB website www.abb.com/solarinverters to find out the make and model of the quick fit connector used on the inverter. 5. Only 50Hz 6. Max. installable size 20A Note: The features that are not specifically mentioned in this data sheet are not included in the product.	

Contact us
 www.abb.com/solarinverters

PVS-50_60-TL-Quick Installation Guide EN-RevB
 EFFECTIVE 18/07/2018
 © Copyright 2018 ABB. All rights reserved.
 Specifications are subject to change without notice.

